

DSP700 SENSOR ASSEMBLY

© 2010 Hunter Engineering Company

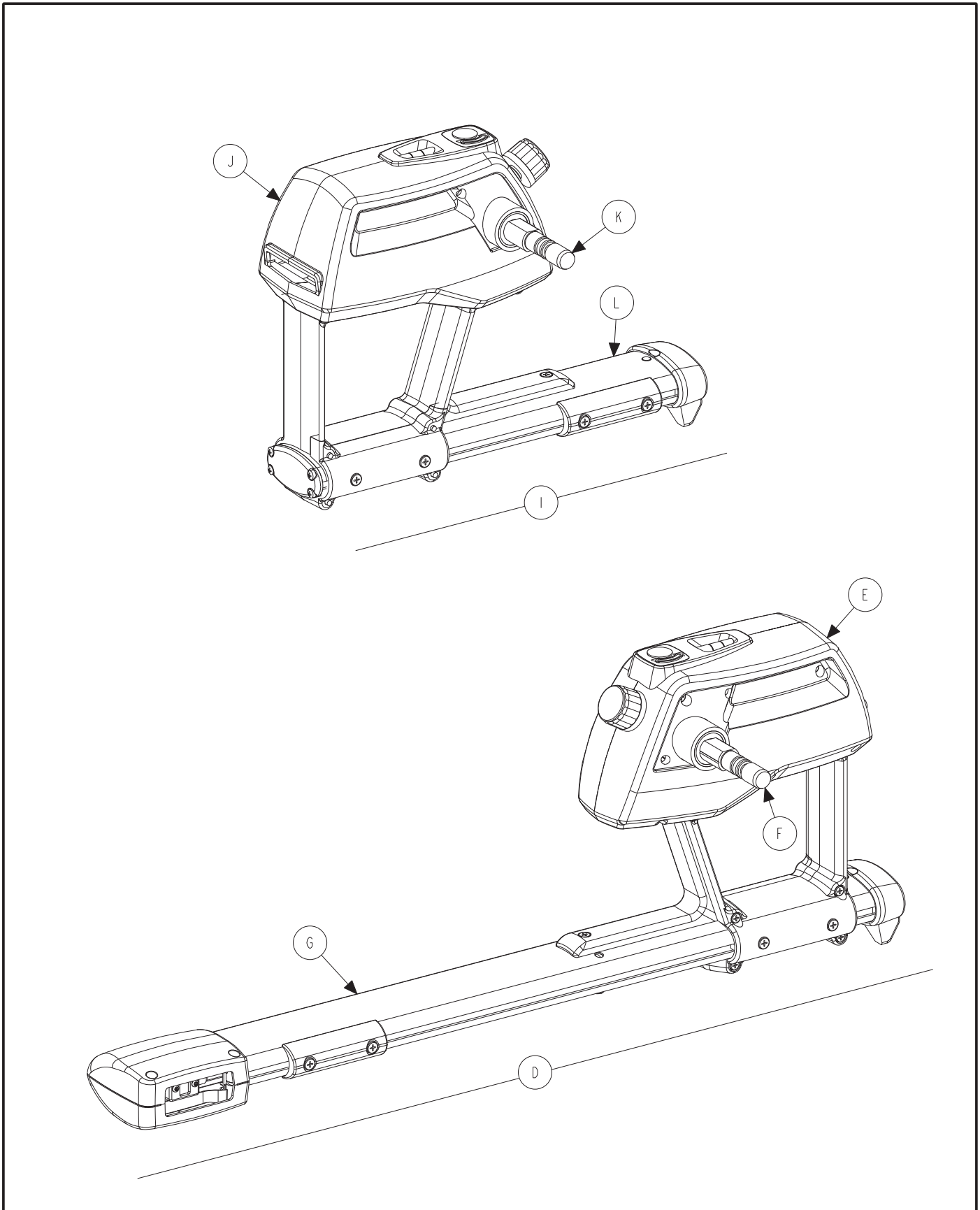

DSP700 SENSOR ASSEMBLY
REFER TO NEXT SHEET FOR PARTS DESCRIPTION LISTING

PARTS DESCRIPTION LISTING
DSP700 SERIES SENSORS

DSP706 SENSORS

Index No.	Part Number	Description
A	20-2380-1	KIT, WSX STORAGE WITH RECHARGE (Sheet 7) (Not Illustrated)
B	38-1117-2	CABLE, 12VDC, POWER, EXTENSION, (Not Illustrated)
C	232-201-1	ELECTRONIC ASSEMBLY, XF2 POD (Not Illustrated) (Sheet 6)
D	125-427-1	SENSOR, ASSEMBLY RF WSX (Major Components Include:)
E	117-209-1	HANGER, ASSEMBLY RF DSP700 (Sheet 3)
F	11-1328-1	SUPPORT, ASSEMBLY RF / LR WSX (Sheet 4)
G	16-931-1	TUBE ASSEMBLY, TOEARM REAR LEFT WSX (Sheet 5)
H	125-428-1	SENSOR, ASSEMBLY LF WSX (Not Illustrated) (Sheets 3, 4 and 5)
I	125-425-1	SENSOR, ASSEMBLY RR WSX (Major Components Include:)
J	117-207-1	HANGER, ASSEMBLY RR DSP700 (Sheet 3)
K	11-1329-1	SUPPORT, ASSEMBLY LF / RR WSX (Sheet 4)
L	16-930-1	TUBE ASSEMBLY, TOEARM FRONT WSX (Sheet 5)
M	125-426-1	SENSOR, ASSEMBLY LR WSX (Not Illustrated) (Sheets 3, 4 and 5)

DSP708 SENSORS

Index No.	Part Number	Description
A	20-2380-1	KIT, WSX STORAGE WITH RECHARGE (Sheet 7) (Not Illustrated)
B	38-1117-2	CABLE, 12VDC, POWER, EXTENSION, (Not Illustrated)
C	232-201-1	ELECTRONIC ASSEMBLY, XF2 POD (Not Illustrated) (Sheet 6)
D	125-427-1	SENSOR, ASSEMBLY RF WSX (Major Components Include:)
E	117-209-1	HANGER, ASSEMBLY RF DSP700 (Sheet 3)
F	11-1328-1	SUPPORT, ASSEMBLY RF / LR WSX (Sheet 4)
G	16-931-1	TUBE ASSEMBLY, TOEARM REAR LEFT WSX (Sheet 5)
N	125-428-1	SENSOR, ASSEMBLY LF WSX (Not Illustrated) (Sheets 3, 4 and 5)
O	125-440-1	SENSOR, ASSEMBLY RR DSP708 (Not Illustrated) (Sheets 3, 4 and 5)
P	125-439-1	SENSOR, ASSEMBLY LR DSP708 (Not Illustrated) (Sheets 3, 4 and 5)

Sensor / component location nomenclature:

- RF – Right Front
- LF – Left Front
- RR – Right Rear
- LR – Left Rear

Due to the interchangeable design of sensors, the component name will not always match sensor location.

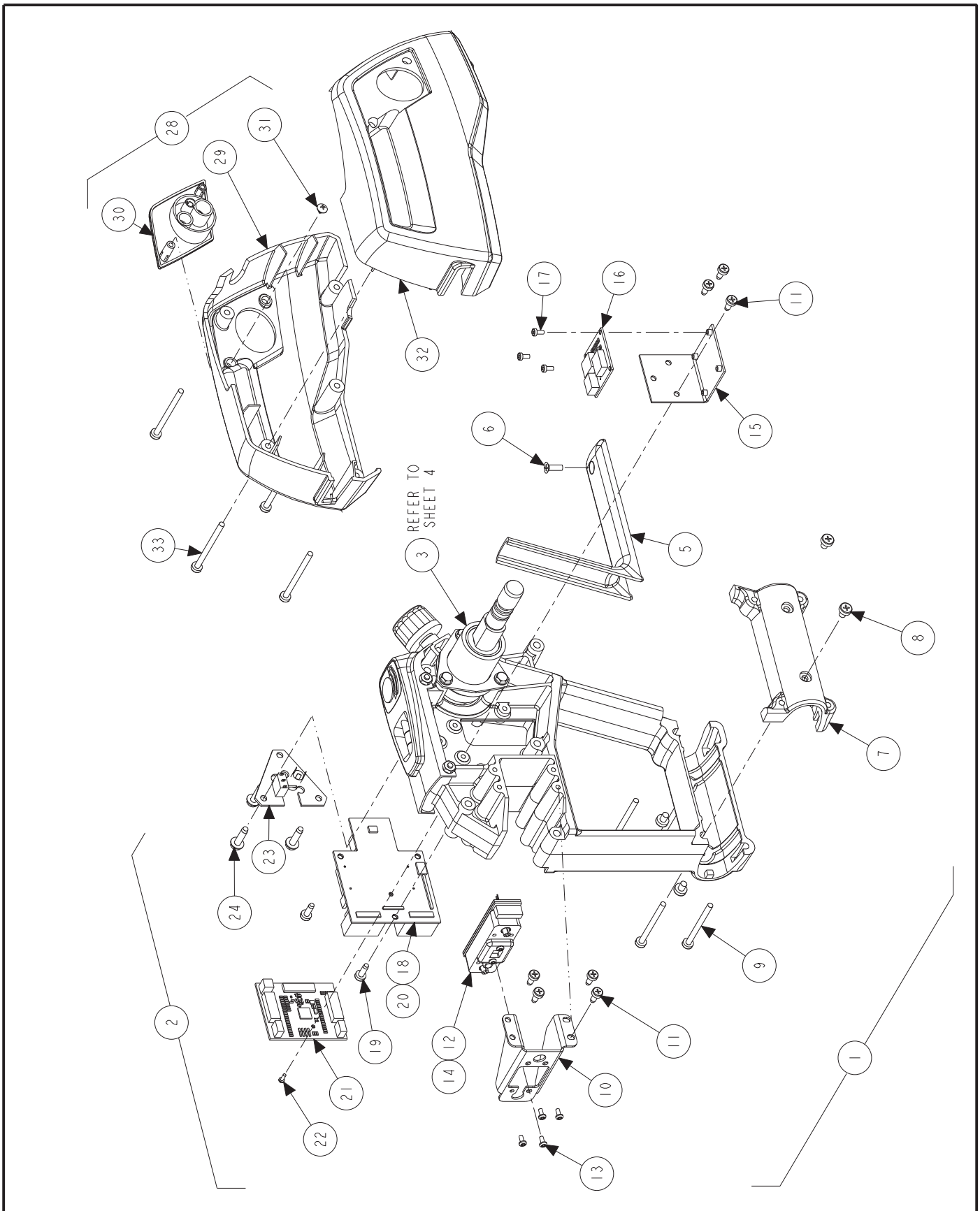

DSP700 SENSOR ASSEMBLY
 REFER TO NEXT SHEET FOR PARTS DESCRIPTION LISTING

PARTS DESCRIPTION LISTING

Index No.	Part Number	Description	706 RR	708 RR	706 LR	708 LR	706 708 RF	706 708 LF
1	125-425-1	SENSOR,ASSEMBLY RR WSX (Consisting Of:)	1					
OR	125-426-1	SENSOR, ASSEMBLY LR WSX (Consisting Of:) (Not Illus.)			1			
OR	125-427-1	SENSOR, ASSEMBLY RF WSX (Consisting Of:) (Not Illus.)					1	
OR	125-428-1	SENSOR, ASSEMBLY LF WSX (Consisting Of:) (Not Illus.)						1
OR	125-439-1	SENSOR, ASSEMBLY LR DSP708 (Consisting Of:) (Not Illus.)				1		
OR	125-440-1	SENSOR, ASSEMBLY RR DSP708 (Consisting Of:) (Not Illus.)		1				
2	117-207-1	HANGER, ASSEMBLY RR DSP700(Consisting Of:)	1					
OR	117-208-1	HANGER, ASSEMBLY LR DSP700 (Consisting Of:) (Not Illus.)			1			
OR	117-209-1	HANGER, ASSEMBLY RF DSP700 (Consisting Of:) (Not Illus.)				1	1	
OR	117-210-1	HANGER, ASSEMBLY LF DSP700 (Consisting Of:) (Not Illus.)		1				1
3	11-1329-1	SUPPORT, ASSEMBLY LF/RR WSX (Sheet 4)	1	1				1
OR	11-1328-1	SUPPORT, ASSEMBLY RF/LR WSX (Sheet 4) (Not Illus.)			1	1	1	
4	16-930-1	TUBE ASSEMBLY, TOEARM FRONT WSX (Sht 5) (Not Illus.)	1		1			
OR	16-931-1	TUBE ASS'Y, TOEARM REAR LEFT WSX (Sht 5) (Not Illus.)				1	1	
OR	16-932-1	TUBE ASS'Y, TOEARM REAR RT WSX (Sheet 5) (Not Illus.)		1				1
5	69-1303-2	COVER, WIRE REAR WSX	1	1	1	1	1	1
6	75-576-2	SCREW, SELF-TAPPING 8-32 X .50 INCH	1	1	1	1	1	1
7	11-1322-2	SUPPORT, TOEARM RETAINER WSX	1	1	1	1	1	1
8	75-608-2	PAN HEAD MACHINE SCREW 10-32 X .31 INCH	6	4	6	4	4	4
9	75-724-2	PAN HEAD MACHINE SCREW 8-32 X 2.0 INCH	4	4	4	4	4	4
10	14-1196	BRACKET, LONG TOE DSP700	1	1	1	1	1	1
11	75-326-2	SCREW, SELF-TAPPING 8-32X5/16 INCH	7	7	7	7	7	7
12	105-564-1	HOUSING ASSEMBLY, WSX 26 DEG LONG TOE FRONT	1	1	1	1	1	1
13	75-721-2	SCREW, SELF-TAPPING MAG MG3 X 1.0 6 MM LONG	4	4	4	4	4	4
14	38-976-1	CABLE, DSP500 LONG. TOE 5.5 INCH	1	1	1	1	1	1
15	14-1197-1	BRACKET, MEMS-DUAL-AXIS	1	1	1	1	1	1
16	45-1275-1-1	PCA, DSP700 CAM/CAS	1	1	1	1	1	1
17	75-612-2	PAN HEAD MACHINE SCREW, 4-40 X 1/4 INCH	3	3	3	3	3	3
18	45-1229-1	PCA, DSP700 MAIN	1	1	1	1	1	1
19	75-441-2	SCREW, SELF-TAPPING 8-32 X .50 INCH	3	3	3	3	3	3
20	38-801-1	CABLE, DSP300 CASTER, 10 INCH	1	1	1	1	1	1
21	45-1281-1	PCA, DSP700 RADIO MODULE G2	1	1	1	1	1	1
22	75-618-2	PAN HEAD MACHINE SCREW 2-56 X 1/4 INCH	1	1	1	1	1	1
23	41-183-1	RETAIN ASSEMBLY, RECHARGE JK/SW WSX	1	1				1
OR	41-182-1	RETAIN ASSEMBLY, RECHARGE JK/SW WSX			1	1	1	
24	75-731-2	SELF-TAPPING, SWAGE FORM 10-32X.75 INCH	3	3	3	3	3	3
25	24-51-2	NAMEPLATE, HUNTER MODEL & PART (Not Illustrated)	1	1	1	1	1	1
26	128-154-2	DECAL, SENSOR LOCATION WARNING (Not Illustrated)	1	1	1	1	1	1
27	24-161-2	NAMEPLATE, CONV. SENSORS PATENT (Not Illus.)	1	1	1	1	1	1
28	69-1301-1	COVER ASS'Y, LF/RR OUTER WSX (Consisting Of:)	1	1				1
OR	69-1302-1	COVER ASS'Y, RF/LR OUTER WSX (Cons. Of:) (Not Illus.)			1	1	1	
29	69-1283-2	COVER, FRONT WSX	1	1				1
OR	69-1284-2	COVER, REAR WSX			1	1	1	
30	69-1309-3	COVER ASSEMBLY, SWITCH LF WSX	1	1				1
OR	69-1308-3	COVER ASSEMBLY, SWITCH RT WSX			1	1	1	
31	75-719-2	TRUSS HEAD SHEET METAL SCREW 6 X 1/4 INCH	1	1	1	1	1	1
32	69-1284-2	COVER, REAR WSX	1	1				1
OR	69-1283-2	COVER, FRONT WSX (Not Illustrated)			1	1	1	
33	75-726-2	PAN HEAD MACHINE SCREW 8-32 X 2.25 INCH	5	5	5	5	5	5
34	128-1235-2	DECAL, XF4 HIPWR APPROVAL (Not Illustrated)	1	1	1	1	1	1
35	128-1254-2	DECAL, DSP700 SENSOR COVER FRONT (Not Illus.)	1		1			
OR	128-1255-2	DECAL, DSP700 SENSOR COVER REAR (Not Illus.)		1		1	1	1
36	128-390-2	DECAL, SENSOR DISCONNECT POWER (Not Illus.)	1	2	1	2	2	2
37	128-429-2	DECAL, REAR WHEEL DESIGNATION (Not Illus.)		1		1		

PPP-Paint Code Required
A/R-As Required
REF-Reference

HUNTER
Engineering Company

11250 HUNTER DRIVE BRIDGETON, MO 63044

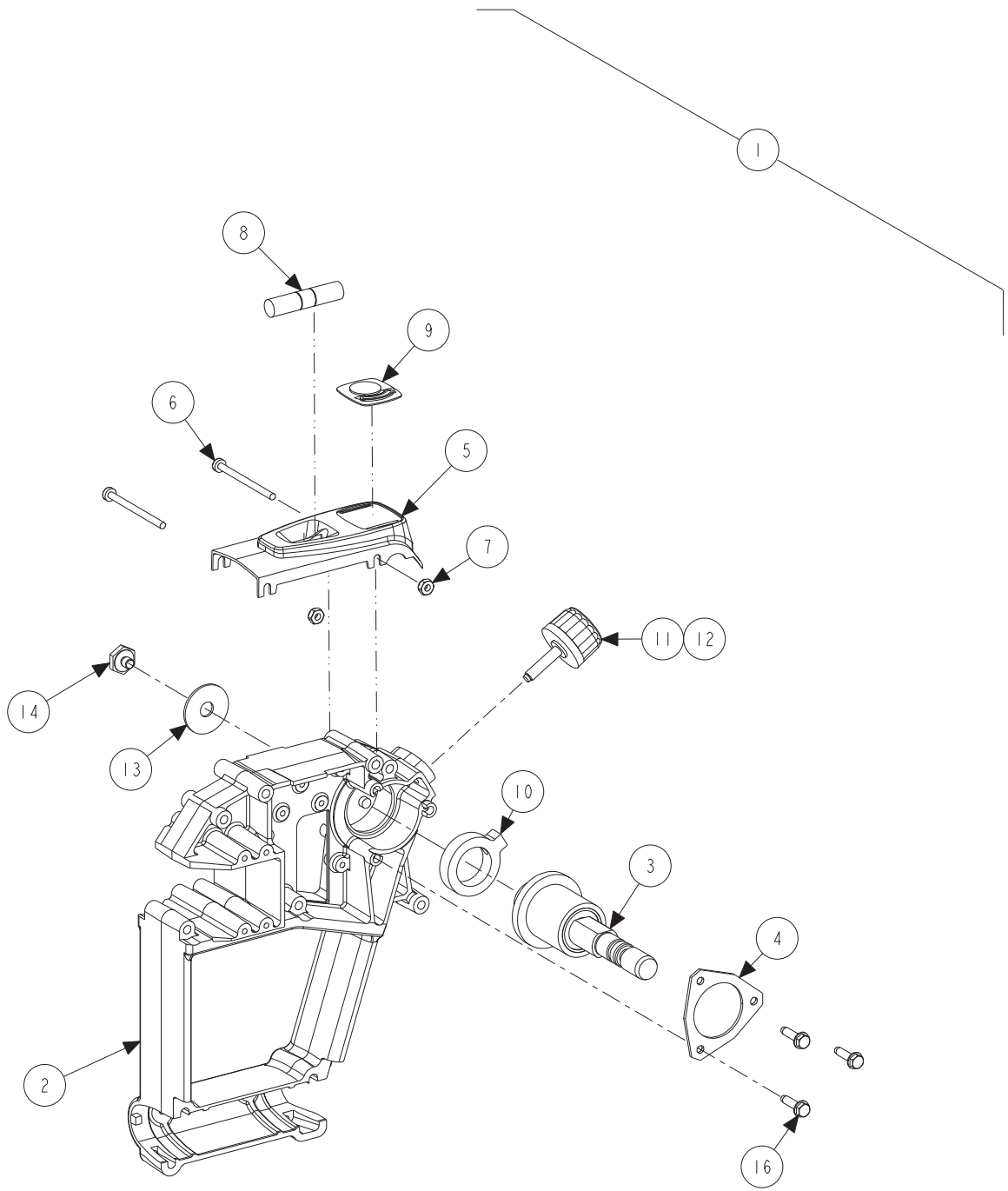

DSP700 SENSOR ASSEMBLY
 REFER TO NEXT SHEET FOR PARTS DESCRIPTION LISTING

PARTS DESCRIPTION LISTING

Index No.	Part Number	Description	Qty.
1	11-1329-1	SUPPORT, ASSEMBLY LF/RR WSX (Consisting Of:)	1
OR	11-1328-1	SUPPORT, ASSEMBLY RF/LR WSX (Consisting Of:) (Not Illustrated)	1
2	11-1321-2	SUPPORT, SENSOR, WSX	1
3	184-87-1	HUB, SENSOR SHAFT WSX	1
4	41-180	RETAIN, BEARING NO FLANGE WSX	1
5	105-558-2	HOUSNG, LEVEL SWITCH DSP700	1
6	75-726-2	PAN HEAD MACHINE SCREW 8-32X2.25 INCH	2
7	76-71-2	NUT, KEPS 8-32	2
8	25-141-2	GAGE, LEVEL VIAL, DSP500	1
9	18-519-2	SWITCH, COMP WSX	1
10	223-56-2	RING, BRAKE	1
11	34-193-3	KNOB, LOCK-700	1
12	FIELD PURCHASE	LOCTITE, ANTISEIZE THREAD COMPOUND 767	A/R
13	41-179-2	RETAINER, SHAFT CLAMP	1
14	76-476-1	NUT ASSEMBLY, MAGNET WSX	1
15	FIELD PURCHASE	LOCTITE, 248 BLUE STICK FORM MEDIUM STRENGTH	A/R
16	75-731-2	SELF-TAPPING, SWAGE FORM 10-32X.75 INCH	3

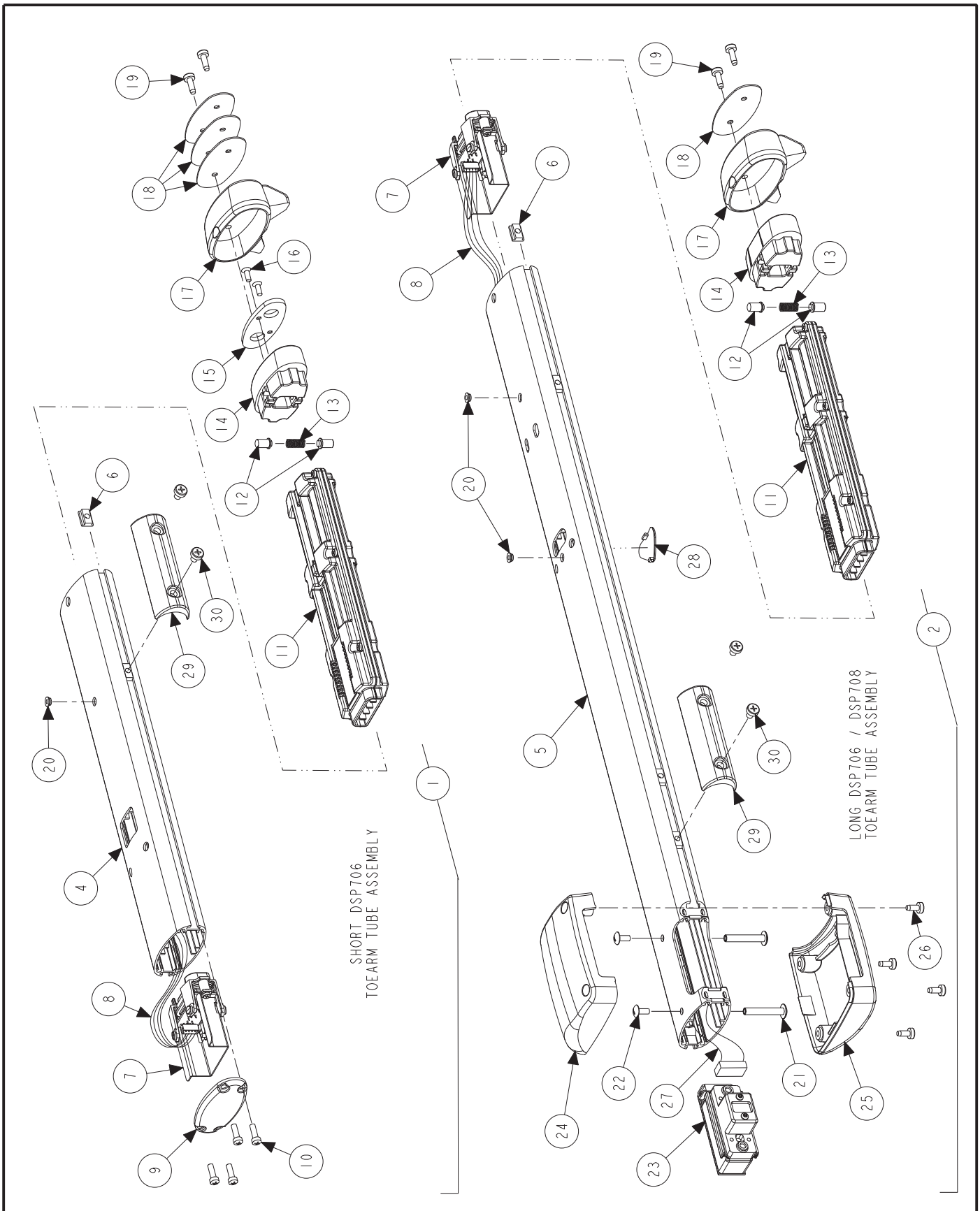

DSP700 SENSOR ASSEMBLY

REFER TO NEXT SHEET FOR PARTS DESCRIPTION LISTING

PARTS DESCRIPTION LISTING

Index No.	Part Number	Description	SHORT DSP706 RR/LR	LONG LR/RF	LONG RR/LF
1	16-930-1	TUBE ASSEMBLY, TOEARM FRONT WSX (Consisting Of:)	1		
2	16-931-1	TUBE ASSEMBLY, TOEARM REAR LEFT WSX (Consisting Of:)		1	
3	16-932-1	TUBE ASS'Y, TOEARM REAR RIGHT WSX (Cons. Of:) (Not Ilus.)			1
4	16-928-2	TUBE, TOEARM FRONT WSX	1		
5	16-917-2	TUBE, TOEARM DSP700		1	1
6	76-382-2	NUT-T	4	6	6
7	36-60-1	RECEPTICAL ASSEMBLY, BATTERY WSX (Includes:)	1	1	1
8	37-586-1	WIRE ASSEMBLY, RECHARGE WSX	1	1	1
9	69-1296-2	COVER, TOEARM CAP WSX	1		
10	75-713-2	SCREW, SELF-TAPPING FLHMS 8-32 X 1/2 INCH	4		
11	194-27-1	BATTERY, PACK HOUSING ASSEMBLY WSX	1	1	1
12	43-143-2	PLUG, PLUNGER WEIGHT WSX	2	2	2
13	98-395-2	SPRING, COMPRESSION C'WEIGHT	1	1	1
14	65-90-2	WEIGHT, COUNTER WEIGHT WSX	1	1	1
15	51-2374-2	PLATE, COUNTER WEIGHT WSX	1		
16	75-714-2	SCREW, SELF-TAPPING FHMS 6-32 X 3/8 INCH	2		
17	53-169-2	CAP, COUNTER WEIGHT WSX	1	1	1
18	51-2351	PLATE, COUNTER WEIGHT DSP700	3	1	1
19	75-441-2	SCREW, SELF-TAPPING 8-32 X .50 INCH	2	2	2
20	76-163-2	NUT, INSERT 8-32	1	2	2
21	76-473-2	NUT, BARREL #8-32 X 1.25 INCH		2	2
22	75-336-2	TRUSS HEAD MACHINE SCREW 8-32 X 3/8 INCH		2	2
23	105-570-1	HOUSING ASSEMBLY, WSX 7.5 DEG TRANS TOE		1	1
24	69-1285-2	COVER, TOE TOP WSX		1	1
25	69-1286-2	COVER, TOE BOTTOM WSX		1	1
26	75-446-2	SCREW, SELF-TAPPING 8-32 X 3/8 INCH		4	4
27	38-988-1	CABLE, DSP506T TRANS TOE 42 INCH		1	1
28	43-144-2	PLUG, TOEARM-HOLE		1	1
29	65-93-2	WEIGHT, ADJUSTABLE BALANCE WSX	REF	1	1
30	75-608-2	PAN HEAD MACHINE SCREW 10-32 X .31 INCH	REF	2	2

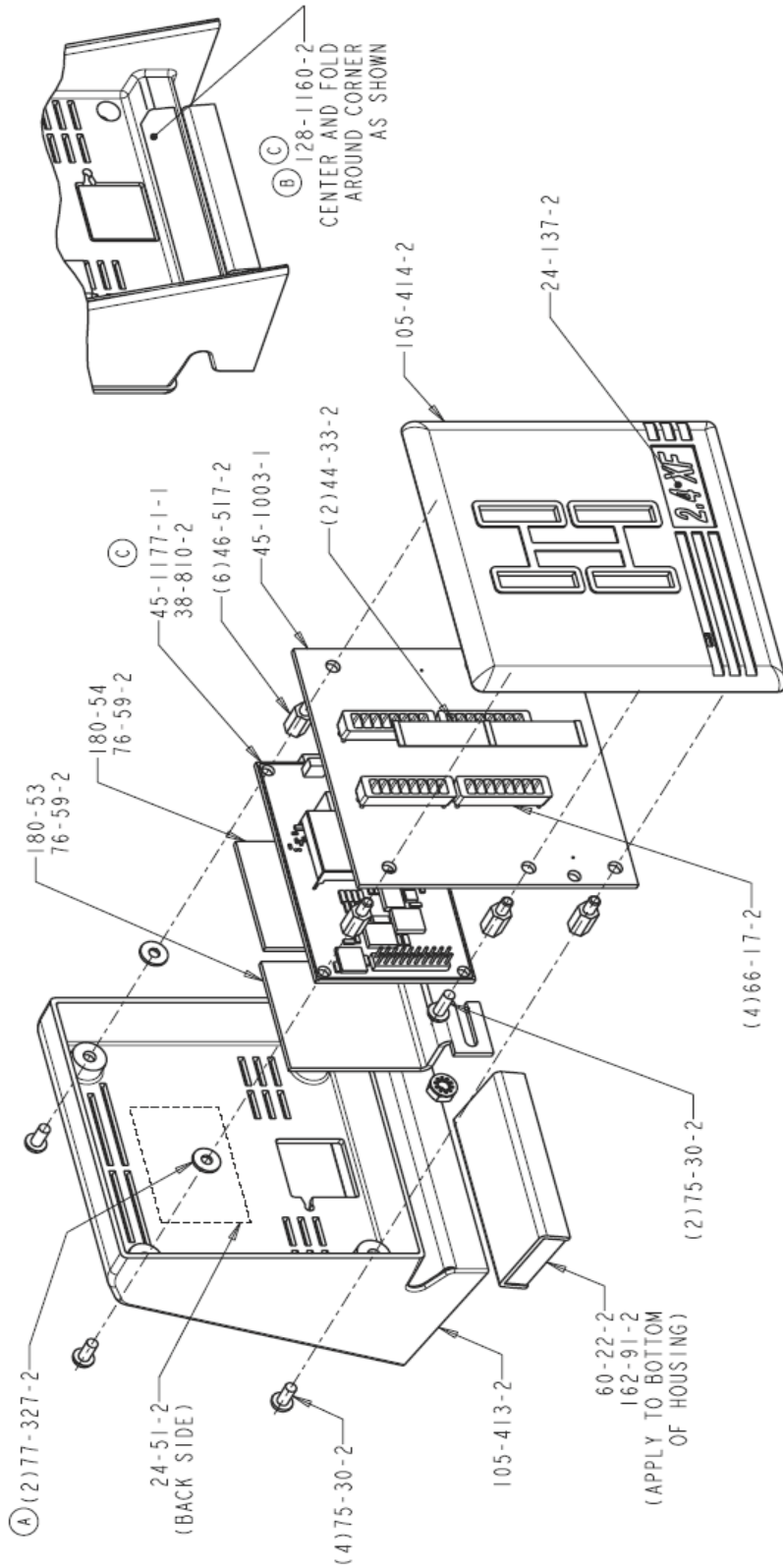

XF2 POD ASSEMBLY

REFER TO NEXT SHEET FOR PARTS DESCRIPTION LISTING

PARTS DESCRIPTION LISTING

Index No.	Part Number	Description	Qty.
1	232-201-1	ELECTRONIC ASSEMBLY, XF2 POD (Consisting Of:)	1
2	105-414-2	HOUSING, FRONT 2.4 XF POD	1
3	105-413-2	HOUSING, REAR 2.4 XF POD	1
4	46-517-2	STANDOFF, 3/16 INCH HEX 5/16 INCH LONG 4-40	6
5	75-30-2	ROUND HEAD MACHING SCREW 4-40X1/4 INCH	6
6	77-327-2	WASHER, NYLON .277 OD X .108 INCH ID	2
7	45-1003-1	PCA, XF POD	1
8	38-810-2	CABLE, 8COND PHONE W/CONN'S 6'	1
9	66-17-2	SEPARATOR LED 2.4 XF POD	4
10	180-53	HEATSINK LEFT-HAND, MINIPOD	1
11	180-54	HEATSINK RIGHT-HAND, MINIPOD	1
12	76-59-2	NUT, KEPS 4-40	2
13	60-22-2	MAGNET, CHANNEL	1
14	44-33-2	WINDOW, RED FILTER 2.4 XF POD	2
15	162-91-2	TAPE, FOAM .03 THICK	2 IN
16	24-137-2	NAMEPLATE, 2.4 XF	1
17	24-51-2	NAMEPLATE, HUNTER MODEL & PART	1
18	128-1160-2	DECAL, XF2 HIPWR APPROVAL	1
19	45-1177-1-1	ZIGBEE RADIO G2	1

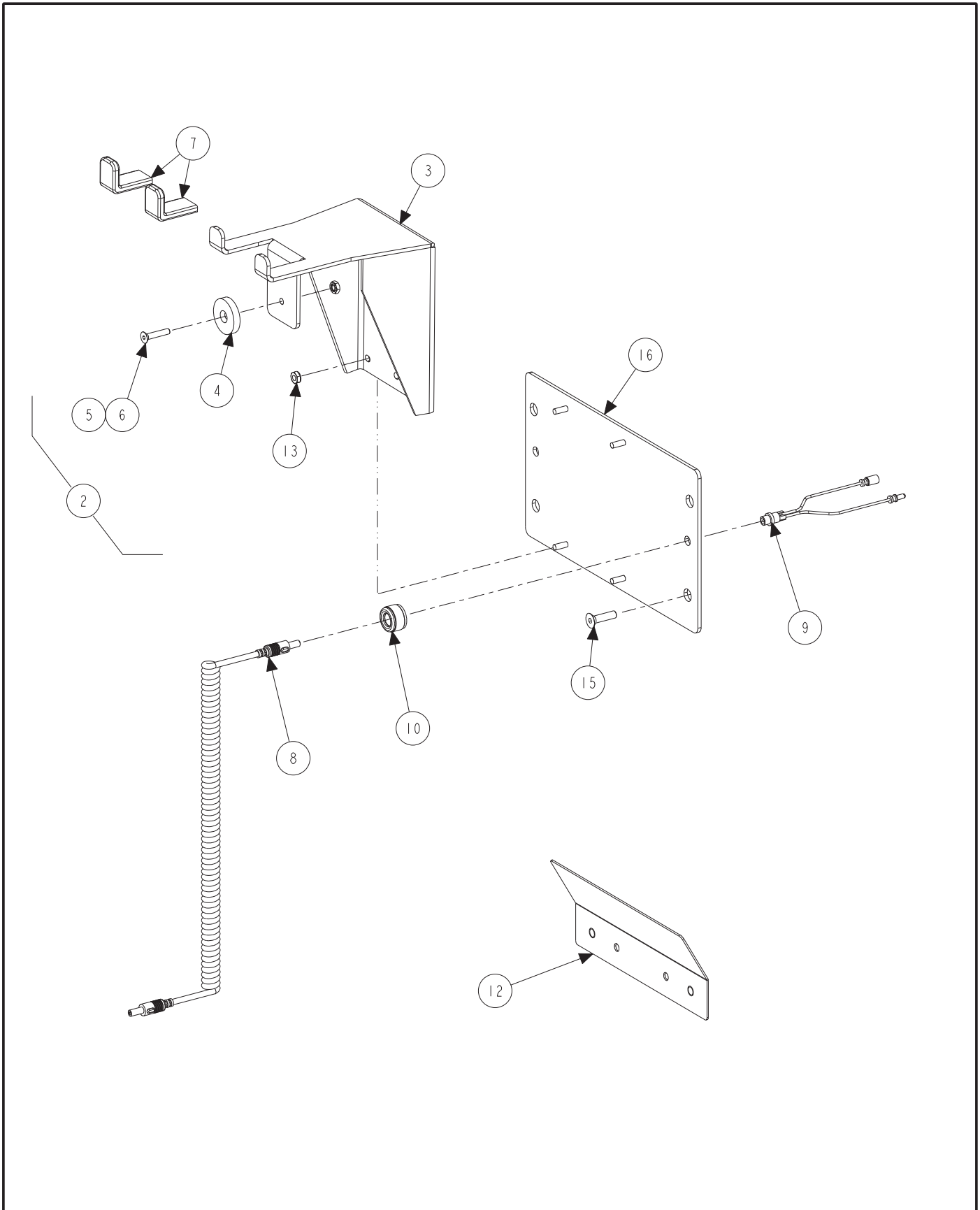

STORAGE KIT, 20-2380-1
REFER TO NEXT SHEET FOR PARTS DESCRIPTION LISTING

PARTS DESCRIPTION LISTING

Index No.	Part Number	Description	Qty.
1	20-2380-1	KIT, WSX STORAGE WITH RECHARGE (Not Illustrated) (Consisting Of:)	1
2	11-1345-1	SUPPORT, DUAL POSITION, ADAPTOR MOUNT	4
3	11-1347	SUPPORT, DUAL POSITION MOUNT	1
4	62-50-2	FOOT, 1/4 INCH RUBBER, 1.25 INCH DIAMETER	1
5	75-93-2	FLAT HEAD SOCKET CAP SCREW 10-32 X 1.00 INCH	1
6	76-61-2	NUT, KEPS 10-32	1
7	106-168-2	SLEEVE, RECTANGAR 10 GAGE	2
8	38-1103-2	CABLE, COILED SENSOR RECHARGE	4
9	38-1109-1	CABLE, RECHARGE SOCKET	4
10	41-195-2	RETAINER, RECHARGE SOCKET	4
11	20-2187-1	KIT, WALL MOUNT ADAPTOR PLATE (Not Illustrated) (Consisting Of:)	1
12	14-1019-005	BRACKET, REMOTE FIXED	1
13	76-61-2	NUT, KEPS 10-32	16
14	75-599-2	SCREW, SELF TAPPING 1/4-20 X .50 INCH (Not Illustrated)	2
15	75-214-2	FLAT HEAD SOCKET CAP SCREW 1/4-20 X 1.00 INCH	16
16	51-2457-1-005	PLATE, ADAPTOR MOUNT-RF/LR	2
17	51-2458-1-005	PLATE, ADAPTOR MOUNT-LF/RR (Not Illustrated)	2
18	62-50-2	FOOT, 1/4 INCH RUBBER, 1.25 INCH DIAMETER (As Needed, Ref. Form 6056-T)	4